

FOOD PROCESSING LIGHT

BE-HCP06

The Food Processing Light is designed specifically for food processing applications. This fixture meets or exceeds all NSF inspection zone requirements. The streamlined design allows easy cleaning and prevents the build-up of any liquid or particles.

Ideal for high bay lighting anywhere the NSF standards are required including inspection areas, wash-down zones, freezers and more.

KEY FEATURES:

- **IP69K** Highest Level of Protection Against Water and High-Pressure Washdown
- **CRI 93** High Colour Rendering for Inspection Zones
- **Powder Coated** Materials; No Harmful Substances or Chemicals
- **Shatterproof** Polycarbonate Lens
- **No Exposed Screws**
- **Corrosion Resistant and Streamlined** Body Design
- L70 Lifespan of **>100,000 Hours**



SPECIFICATIONS

Luminous Efficacy	125lm/W *Up to 140lm/W Available Upon Request
CCT	4000K, 5000K (Standard)
CRI	>Ra 90 *(>Ra80)
Beam Angle	90°, 120° (Standard)
Input Voltage	LV: 100-277Vac (Standard) HV: 277-480Vac, 50/60 Hz
IP Rating	IP69K
L70 Lifespan	>100,000 Hours
LED Driver	SOSEN
Dimming	Dimmable
Chipset	Nichia
Operating Temp.	-30°C ~ +50°C
Warranty	5 Year Warranty
Certifications	NSF, cUL, UL, CE, RoHS, DLC



LUMENS	LED WATTAGE	HID EQUIVALENT
30,000 lm	240W	800W
24,000 lm	200W	700W
18,000 lm	150W	600W
12,000 lm	100W	250W

MOUNTING OPTIONS

LOOP HANGING	WALL MOUNT	SURFACE MOUNT	STEM MOUNT
			
STANDARD	BRACKET 15	BRACKET 21	THREAD: 3/4" NPT

FIXTURE ORDERING MATRIX

Product Name	Wattage	Lens Degree	Input Voltage	CCT	Options
BE-HCP06	100W	D90	LV 100-277Vac (Standard)	4000K	15 Bracket 15 21 Surface Mount Bracket 21 STM Stem Mount MS Built-In Motion Sensor (Special Order) SC Safety Cable SGS Surge Suppressor
	150W				
	200W	D120 (Standard)	HV AC 277-480Vac	5000K (Standard)	
	240W				

Example: BE-HCP06-100W-D120-LV-5000K-15-SC-SGS

DIMENSIONS & SHIPPING INFORMATION

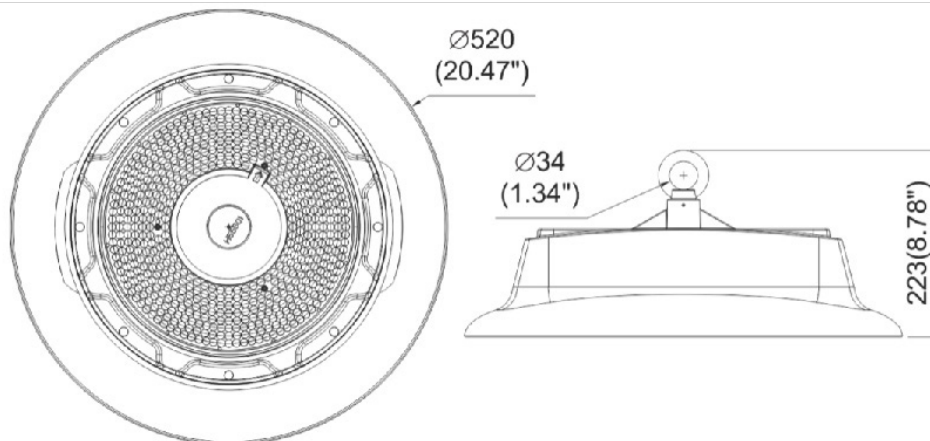

Fixture Weight: 21 lbs

Shipping Weight: 25 lbs

Box Dimensions:
580x580x272mm